

Project No. R1216  
Date: January 27, 2017  
Revised: April 3, 2017  
Humboldt, Saskatchewan

# **Final Report**

## **Identification of Issues Related to Seeding Faba Beans through Air Seeders in Western Canada**

For:  
**Saskatchewan Pulse Growers**  
Saskatoon, Saskatchewan



# Table of Contents

---

	Page
1. Executive Summary.....	1
2. Introduction .....	3
3. Procedure.....	4
4. Results .....	5
4.1 In-Field Visit Locations.....	5
4.2 Field Visit Observations .....	6
4.3 Application Rate and Plant Population .....	15
4.4 Air Seeder Manufacturer Manual Review .....	16
4.5 Comments from Growers Visited .....	21
5. Conclusions.....	22
6. Recommendations.....	23
6.1 Recommendations for Growers .....	23
Appendix A Field Visit Data.....	A-1
Appendix B Phone Survey Data .....	B-1

# 1. Executive Summary

---

Seeded acres of faba beans have increased in Western Canada over the past three years. Due to higher-value markets, faba bean varieties with larger-sized seeds are of particular interest, but there are many issues when seeding the large-seeded faba beans with current air seeders. The main issue has been plugging at various points of the air seeder including the metering system, distribution system, blockage sensors, and at the soil openers.

The seeding difficulties, as well as a lack of information on seeding settings and configurations, has led to a reluctance in some growers to seed the large-seeded varieties, which could be considered a barrier to increased production and market penetration. Since faba bean acres are low and the seed size and shape is irregular when compared to other crops grown in Western Canada, manufacturers presumably may not have made it a high priority to optimize air seeding equipment for such a large, unusual seed. The growers that have seeded the large varieties have invested funds and many hours of trial and error to seed faba beans. They have had to make compromises, such as lower-than-recommended seeding rates and/or reduced ground speed, to reduce the faba bean flowrate through the air seeder metering systems, distribution systems, and soil openers.

To better understand the issues and potential solutions with seeding faba beans, a project was initiated by Saskatchewan Pulse Growers and carried out by the Prairie Agricultural Machinery Institute (PAMI). PAMI worked with nine growers in the field while they were seeding and interviewed 20 growers over the phone that had seeded faba beans in 2016. The process involved an in-field investigation to better define the issues, documentation of current settings and configurations, and development of recommendations for researchers, growers, and manufacturers.

Many of the growers interviewed had experienced seeding difficulties in previous years, had developed their own solutions, and had made compromises to avoid plugging and costly downtime. Growers that were new to the large varieties had also gathered recommendations from other growers that had experienced seeding difficulties in the past. As a result of growers' ingenuity and resourcefulness, not as many seeding issues were encountered as expected during the in-field investigations in the spring of 2016 although almost all had experienced some level of frustration at some point.

In summary, the most common seeding issues encountered by growers included:

1. Plugging at the opener, especially with openers where exit dimensions of the seed tube were reduced, the seed delivery tube inside of the opener changed direction, the hose and opener tube were shingled such that the lip of the opener tube acted as

an obstruction to flow, or the secondary distribution hose was deformed when attached to the opener.

2. Plugging at the secondary distribution manifolds.
3. The inability to achieve the recommended seeding rate due to metering limitations.
4. Having to seed at a slower ground speed due to metering limitations and seed flow issues.

The most common solutions enacted or compromises made by growers in order to alleviate seeding issues included:

1. Decreasing ground speed to reduce the seed flowrate through the air seeder.
2. Using extra-coarse metering rollers or augers with a large volume between flutes or flights.
3. Increasing air flow through the distribution system by using maximum fan speed or installing a fan with higher airflow capacity.
4. Reducing the number of tight turns to prevent the innermost openers from reversing in the soil and plugging or restricting flow.
5. Eliminating any sags in distribution hoses.
6. Using the fertilizer tubes of the soil opener to deliver the seed if the fertilizer delivery tube had a larger cross-sectional area than the seed delivery tube.
7. Removing inline blockage sensors that were thought to obstruct flow.
8. Metering seed out of two tanks instead of one in order to reach the desired seeding rate and reduce the flow-rate demand from an individual meter.
9. Sieving out the largest seeds prior to seeding.
10. Reducing the seeding rate if germination percentage was determined to be high.
11. Seeding the field twice over at half the target application rate.
12. Reducing the outside diameter of the metering rollers to increase clearance with the meter housing and reduce the probability of jamming seeds between the roller and housing.
13. Using vertical tower style distribution manifolds. Some vertical towers may be more prone to plugging than other vertical towers.

To avoid plugging issues, the growers interviewed seeded at an average ground speed of 3.4 miles per hour (mph) as compared to most other crops being seeded at an average of 5.0 mph. This correlates to a reduction in seeding productivity of 32%. This may be acceptable for growers if a small percentage of faba bean growers' total seeded acres are seeded to faba beans. For all growers interviewed, average percentage of total acres seeded to faba beans is 9%. However, lower seeding productivity may be a barrier for increasing seeded area of faba beans in the future. Air seeder systems such as the metering system, distribution system, blockage sensor system, and soil openers may need to be better optimized to obtain the application rates required and the productivity expected by most growers.

## 2. Introduction

---

Faba beans have increased in acres in Western Canada over the past few years going from relatively few acres to approximately 180,000 in 2015 and 115,000 in 2016. There is currently a higher-value market for the larger sized faba bean varieties.

Various seed sizes for faba bean varieties range from 0.74 lb (335 g) to over 1.76 lb (800 g) per thousand kernel weight (TKW). The smaller varieties are slightly larger than field peas and are more round in shape in comparison to the larger faba beans, which makes the smaller variety easier to meter and convey through air seeders. With the larger variety faba beans, there are three main issues noticed during seeding:

- The ability to seed at a rate high enough in one pass to target a plant density of 45 plants per square meter.
- The plugging of seeds at various locations throughout the air seeder distribution system.
- Clearance of the seed through the metering system.

Seeding rates can be as high as 6 to 7 bushels per acre (bu/ac) (360 to 420 pounds per acre [lb/ac]) due to the large seed size, depending on germination of the seeds. The ability to seed at this high seed rate in a single pass can be challenging.

Due to the irregular shape and size of the larger faba bean varieties, there can be many areas of seeding systems where plugging can occur and/or difficulties are experienced when clearing the metering system. There are anecdotal accounts of plugging throughout distribution systems, bridging of seed and inability of seed to flow fast enough to feed the metering system, and exceeding the maximum metering capacity. This project was aimed at gaining a better understanding of the main areas of concern and determining potential solutions. The equipment manufacturers contacted throughout this project were aware of the challenges their customers face when seeding large faba beans and are beginning to develop recommendations for seeding faba beans.

To help growers make more informed decisions about planting increased acreage of large faba beans, a better understanding of the seeding issues and limitations is necessary. In order to further support large faba bean production in Western Canada, the difficulties facing growers need to be identified and a partnership with seeding equipment manufactures established to determine appropriate solutions.

### 3. Procedure

---

The project involved visiting nine growers in their fields during the seeding of faba beans. All participating growers were seeding a large-size seed variety, most commonly FB9-4. Information gathered during these visits included data such as seeding speed, target seeding rate, fan speed, acres seeded to faba beans, thousand kernel weight (TKW), and other machine settings. A second visit occurred 21 to 22 days after seeding involved conducting plant counts to determine if recommended plant population of 45 plants per square metre was being achieved. An additional 20 growers were interviewed in person or over the phone to gather general comments on their experiences seeding faba beans.

Recent operator manuals of five common air seeder manufacturers were reviewed to extract each of their recommendations for seeding faba beans. Also, representatives of the same five air seeder manufacturers were interviewed to document recent customer difficulties and their recommendations for seeding faba beans with their specific air seeder models.

All of the information gathered was later analyzed to

- identify the specific areas of the air seeder that were causing seeding issues,
- identify the remedies that growers claimed were overcoming the issues, and
- document the settings and configurations employed by growers to determine if the settings achieved the recommended plant population.

## 4. Results

The following sections discuss the project results. **Appendix A** contains a complete database of all data collected during the nine in-field visits. **Appendix B** contains a complete database of all data collected by phone interviews with 20 additional growers.

### 4.1 In-Field Visit Locations

In-field visits of nine air seeders during seeding operations were made during the 2016 seeding season to observe and document areas of concern identified by growers when seeding large-seed faba beans. A variety of tool bars, air carts, and opener models were targeted. The in-field visit locations shown in **Figure 1** were near the following centers in Saskatchewan (Yorkton, Canora, Watson, Naicam, Lake Lenore, Ridgedale [two Growers], Medstead, and Speers).

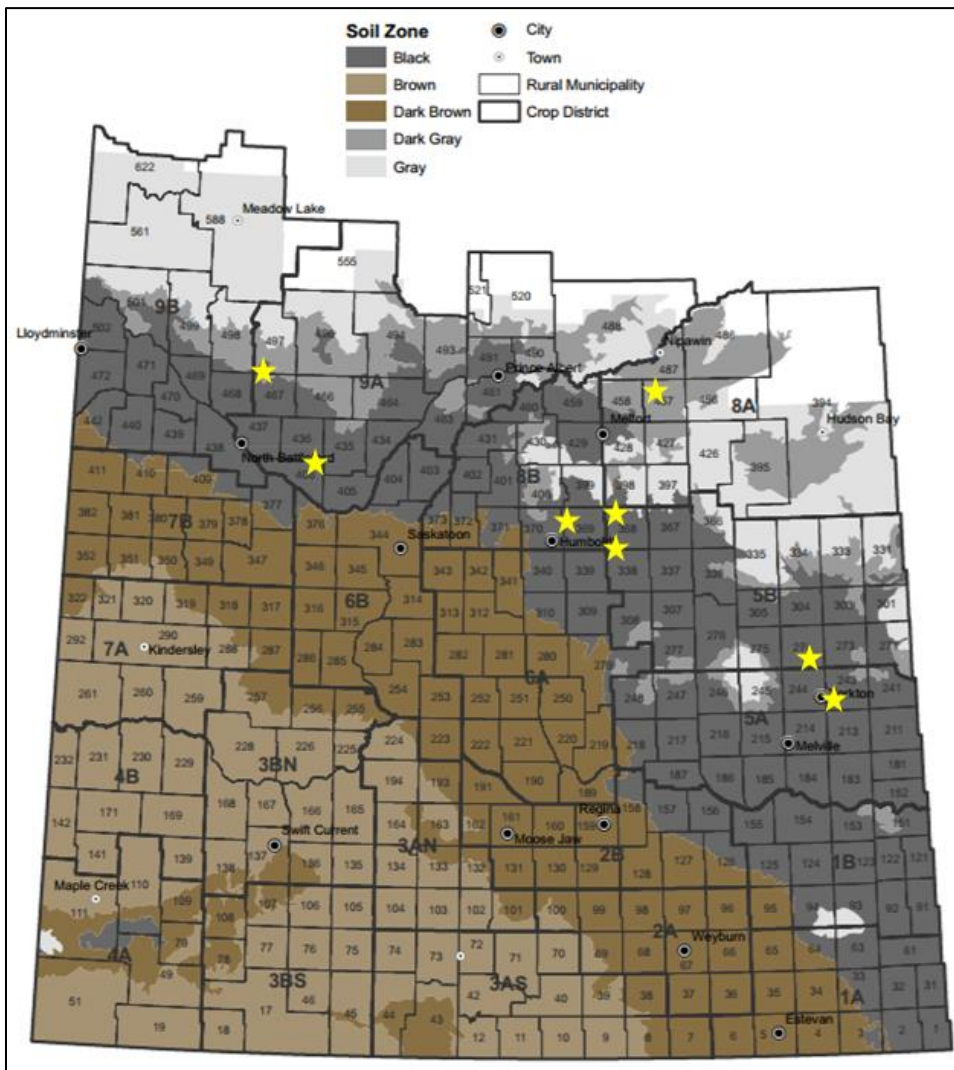

**Figure 1.** Field visit locations (Source: Saskatchewan Ministry of Agriculture).

## **4.2 Field Visit Observations**

Faba beans were a small percentage of most of the growers' total seeded acreage, so most were satisfied with making small compromises to get the seed in the ground without experiencing plugging issues. Many of the growers experienced plugging issues seeding faba beans in previous years or were aware of others that had issues, so most were proactive in setting their equipment to avoid plugging. The growers that seeded faba beans in previous years learned the limitations of their specific seeding equipment through trial and error and most had made modifications to their air seeders. As a result of the actions taken by the growers, minimal seeding issues were observed during the field visits.

There are a wide variety of air seeder toolbars and cart models available on the market. However, all air seeders currently employ the same functional concept. Product (seed or fertilizer) is metered out of bulk storage tanks mounted on an air cart into an airstream that conveys the product to the openers through a distribution system mounted to the toolbar, which consists of a series of primary hoses, distribution manifolds, and secondary hoses. The secondary hoses feed into soil openers that create a trench in the soil for the fertilizer and seed to be placed into.

When considering only the distribution function of transporting the seed from the product tank to the soil, the subsystems that vary between manufacturers are listed below. PAMI's field observations have been categorized into the following subsystems and will be discussed in the following sections.

- Product tank
- Product metering system: type and quantity
- Air seeder fan: size and quantity
- Product distribution system:
  - inside diameter of primary hoses,
  - number of primary hoses,
  - type of distribution manifolds,
  - inside diameter of secondary hoses (after manifolds), and
  - number of secondary hoses
- Blockage monitor system
- Soil opener

### **4.2.1 Product Tank**

There were no issues observed with bridging of product in the tanks of any of the air seeders visited.

### **4.2.2 Product Metering System**

Manufacturers offer many different metering roller options. The recommended metering rollers typically correlate with the size of the seed and target application rates. For



example, **Figure 2** shows options for Case and New Holland air carts. The metering roller on the left is the extra coarse option for very large seeds and high application rates, and the one on the right is the coarse option.

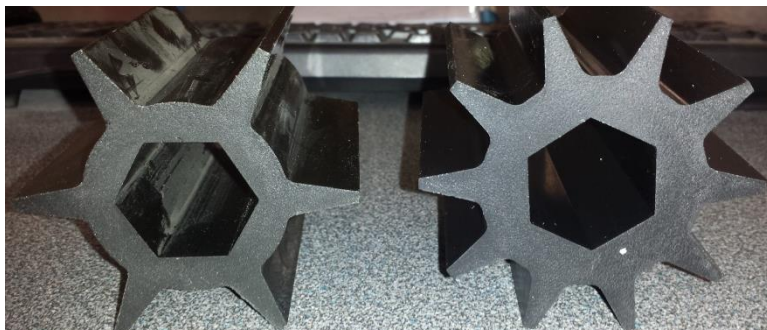

**Figure 2.** New Holland and Case IH extra-coarse (left) and coarse (right) metering roller options.

Instead of metering rollers, Bourgault air carts use different types of metering augers. Some Bourgault air carts have an orifice installed where the auger drops the seed into the air stream; this decreases the clearance between the auger and the auger housing in an effort to reduce the chance of product bypassing the metering auger. For large seeds, Bourgault recommends removing this orifice to reduce the occurrence of seeds jamming between the metering auger and the auger housing.

No plugging issues were observed at the metering system of any of the seeding units, although most growers had reduced their ground speed, reduced their target application rate, seeded their field twice over, or delivered seed out of two different tanks in order to reduce the application rate demand on the metering system. Some of these growers interviewed by phone also had experienced problems with plugging the metering system. Average ground speed was only 3.5 mph for all growers visited, as compared to the typical ground speed of 5.0 mph when seeding traditional crops.

#### **4.2.3 Air Seeder Fan**

All growers set the fan speed as recommended in their air seeder's operator's manuals. Average fan speed was 4,830 revolutions per minute (rpm), although all fan and air distribution systems are different, so a specific fan speed recommendation for all air seeders is not meaningful. Volumetric flow and velocity are more meaningful measurements than just fan speed. Unfortunately, it was not possible to obtain these measurements on a producer-owned machine during seeding. There is a tendency for most growers to maintain a fan speed at the high end of the recommended range to reduce the likelihood of seeds plugging the distribution system. Potential disadvantages of having the fan speed set too high are that the seed may bounce out of the seed trench, and/or excessive seed velocity and impacts with the distribution system components may cause seed damage and result in reduced emergence. More research is required to determine optimal volumetric flow and velocity of large, oddly shaped seeds such as faba beans, and the subsequent impact on seed quality and emergence.

Some manufacturers offer high-capacity fan options as shown in **Figure 3**. The high capacity fan option potentially better facilitates high application rates of product.

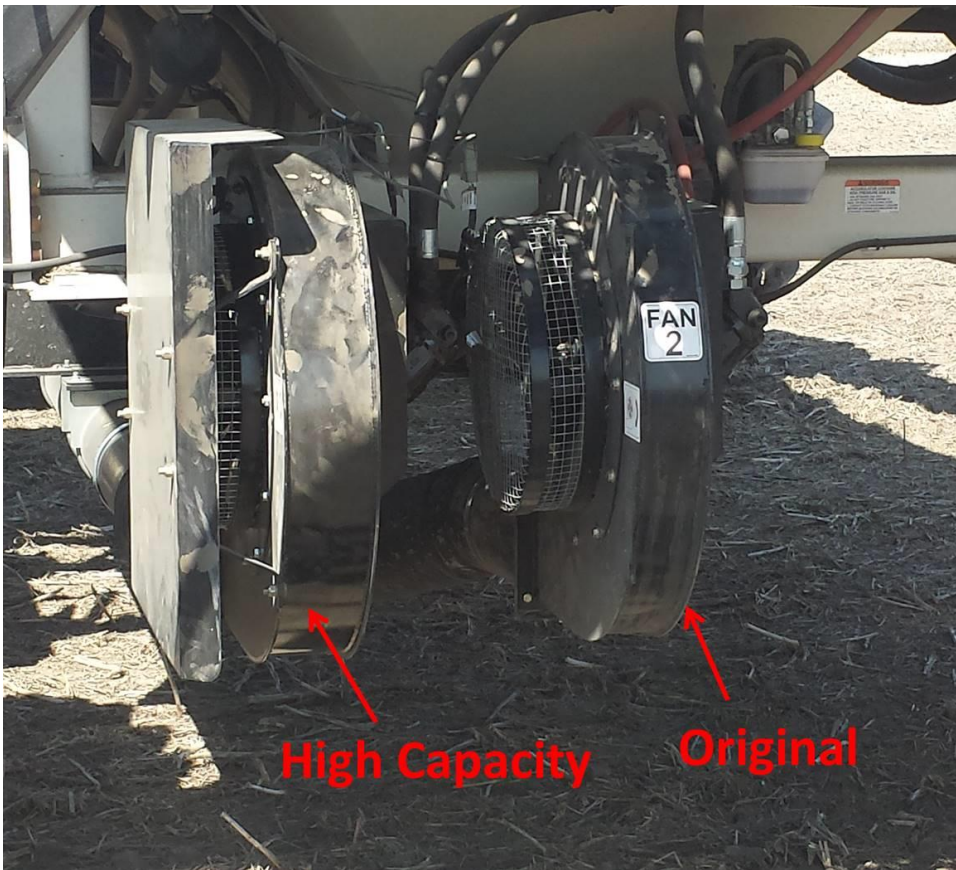

**Figure 3.** High capacity fan option from Bourgault.

#### **4.2.4 Product Distribution System**

The product distribution system of an air seeder includes the primary hoses, the distribution manifolds, and the secondary hoses. The growers visited in the field all had the same size: 2.5 in. primary and 1 in. secondary hoses. The number of primary hoses varied from four to eight hoses depending on the width of the toolbar, and the number of secondary hoses varied from 8 to 12 hoses per distribution manifold. The Bourgault distribution system is slightly different in that the product flow is divided twice prior to reaching the secondary hoses that feed the openers.

The two main types of distribution manifolds encountered in the field were the tower type (**Figure 4**) used by many manufacturers and the flat-fan type (**Figure 5**) used by Morris. Some growers surveyed preferred the tower-type distribution manifolds over the flat-fan style. Some had replaced the flat-fan distribution manifolds with tower-type manifolds. The theory offered by growers regarding the flat-fan manifolds was that the transition from the large, round primary hose into the square tubes that fed the secondary hoses was an area where large faba beans could potentially plug. Morris has recently offered a

flat-fan distribution manifold with larger openings for the transition into the secondary hoses, which may alleviate the plugging issue. No testing has been conducted by PAMI to validate these grower's theories, or the manufacturer's proposed solution.



**Figure 4.** Tower type distribution manifold.



**Figure 5.** Morris flat-fan type distribution manifold.

Routing of distribution hoses is an important factor for good product flow when seeding any crop with an air seeder. Hose routing is especially important when seeding large, oddly shaped faba beans at a high application rate. All growers recommended to ensure there were no sags or tight radius bends in primary or secondary hoses to reduce the instances of plugging. For example, the hose in **Figure 6** was located on the outer-most distribution manifold of an 80 ft toolbar. The producer had installed a higher-capacity fan on his air cart; however, the hose sag still resulted in a plugged hose.



**Figure 6.** Sag in secondary hose caused a plug.

One type of the tower-style distribution manifold used screws to secure the secondary hoses to the distribution manifolds (**Figure 7**). Some of these screws were replaced by the producer with screws that were 1/4 in. longer than the production screws. While the longer screws did not cause any product flow issues for smaller seeds, they did increase the frequency of plugging when seeding large faba beans.



**Figure 7.** Screws used to secure secondary hoses to the distribution manifold.

#### **4.2.5 Blockage Monitoring Systems**

There are many different types and suppliers of blockage monitors on the market. Three of the nine growers visited had blockage monitor systems installed; however, only one had the blockage system activated. **Figure 8** and **Figure 9** show a straight-through design while **Figure 10** shows a flow path detour, and **Figure 11** shows a 90 degree change in direction in product flow. Many of the growers interviewed recommended not

having any blockage sensors installed for fear of obstructing product flow. However, this perception has not been proven.



**Figure 8.** Straight-through blockage sensor.



**Figure 9.** Straight-through blockage sensor.



**Figure 10.** Blockage sensor with some flow path alteration.



**Figure 11.** Blockage sensor with 90 degree path change.

All types of blockage sensors reportedly caused issues for the growers. Growers found the blockage sensors would often give a false reading, which caused the operator to stop for an inspection. Growers also stated that the sensors would inhibit product flow due to a change in direction or improper shingling of the sensor lip with the hose when installed in line. Many of the growers had removed their blockage sensors when seeding faba beans to avoid these issues. Growers recommended that lips be removed from inside the sensor where seeds can catch. Also, the internal diameter of the sensor should match the internal diameter of the hose to eliminate flow obstructions.

#### **4.2.6 Soil Openers**

The soil openers were the most common source of plugging for the growers. There are a wide variety of soil openers that can be purchased from each air seeder manufacturer or from aftermarket manufacturers. Most styles of openers can be installed onto a variety of tool bars. The seed inlets and outlets of the various openers vary in shape and cross-sectional area. Through field observation, it was found that the probability of plugging increased if there are any obstructions, change in shape, or change in direction of the

seed flow through the opener. Many openers on the market today have a narrow exit for more precise seed placement. This is fine for small seeds; however, for large-sized seeds the narrowing of the seed tube of some openers, such as the openers shown in **Figure 12**, increased the frequency of plugging.



**Figure 12.** Narrow exit of seed tube.

Openers with straight-through geometry and no obstructions or change in directions (**Figure 13**) were found to reduce the probability of plugging.



**Figure 13.** Straight through opener (rear hose applies seed).

Some growers swapped the fertilizer and seed placement hoses if the fertilizer path was a more direct route for the kernels to flow into the soil trench, like the center delivery tube on a paired row opener (**Figure 14**). Typically, the fertilizer would be applied through the center outlet, however in order for seeds to exit the side outlets they would have had to change direction which may have slowed the faba beans down and caused a plug.

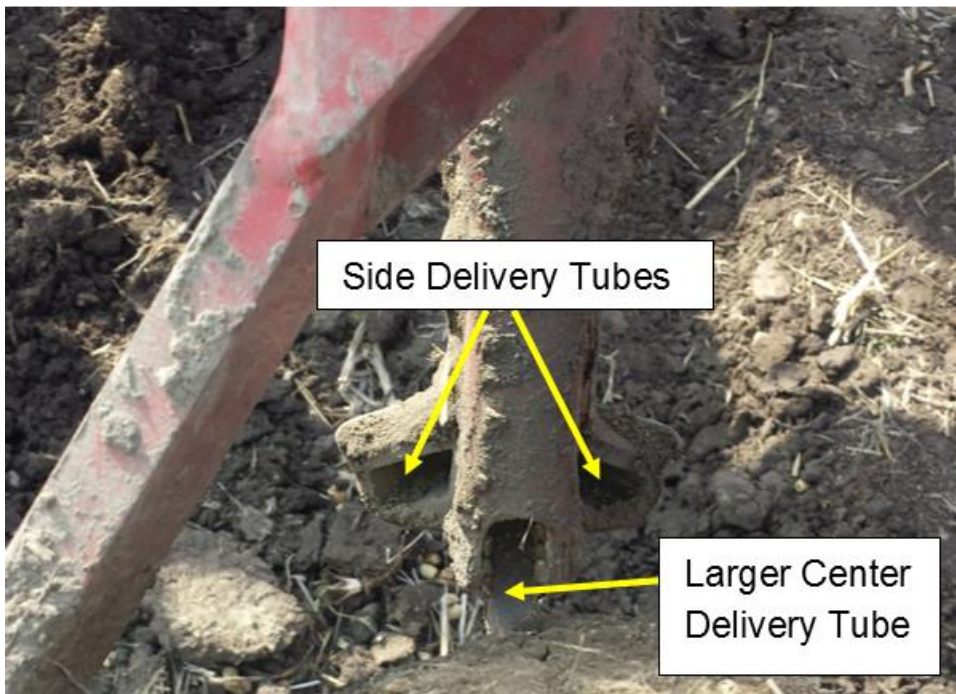

**Figure 14.** Routing of seed through the larger, center fertilizer opening of a paired row opener.

Another potential point of product flow restriction on most toolbars was where the hose attaches to the top of the opener. If the hose clamp was too tight, the plastic hose collapsed, creating a pinch point that potentially obstructed flow (**Figure 15**).



**Figure 15.** Collapsed hose due to an overtight hose clamp.



Some growers stated that turning too sharply while seeding can lead to seed backup into the opener outlet and secondary hoses since the inside openers are travelling very slow or are virtually stalled in place during a sharp turn.

### **4.3 Application Rate and Plant Population**

The size of the faba beans for the nine growers visited as expressed in thousand kernel weight (TKW) varied from 1.20 lb (546 g) to 1.74 lb (787 g) per 1000 seeds with an average of 1.44 lb (655 g) per 1,000 seeds. In an attempt to reduce the probability of plugging in their air seeder, two growers screened out the largest seeds prior to seeding, leaving only the smaller seeds to be planted. One producer screened out the smaller seeds because he believed the small seeds had less vigor than the larger seeds. The remaining growers did not want to spend the time and expense on seed cleaning.

Ground speed, metering roller or auger speed, volume between the metering roller flutes or auger flights, and seed size largely determines the maximum possible application rate for each air seeder. Some of the commodity carts used by the growers could not achieve the necessary high application rate while traveling at typical seeding speeds of 5.0 miles per hour (mph), so various strategies were used to achieve the target rates. One producer metered seed out of two air cart tanks to achieve a total application rate of 240 lb/acre at 3.1 mph. Another producer seeded the field twice over at 2.2 mph to achieve a total application rate of 360 pounds per acre (lb/ac). A third producer used an older, 30 ft wide box drill to apply seed at 250 lb/ac at a ground speed of 5.3 mph, since he had plugging issues with his air seeder over the past two years.

Most growers were being cautious to avoid plugging. The most common strategy employed was to reduce their ground speed from typical seeding speeds. Ground speed of all nine growers ranged from 2.2 mph to 5.3 mph with an average of 3.5 mph. The width of toolbars used ranged from 30 ft to 84 ft and averaged 58 ft. The area coverage rate, which takes into account ground speed and toolbar width, ranged from 14.7 acres per hour (ac/hr) to 47.9 ac/hr for an average of 24.9 ac/hr. When seeding typical Saskatchewan crops such as canola or cereals, growers are travelling at approximately 5 mph, which with a 58 ft wide toolbar equates to an estimated area coverage rate of 35.2 ac/hr. Almost all growers were sacrificing seeding productivity to avoid plugging.

It became apparent that to achieve the high application rates for faba beans, many growers were using strategies and air seeder configurations that were different from what they would normally have used when seeding other typical Saskatchewan crops. Some of the strategies and configurations could be considered compromises in an effort to get the seed in the ground. PAMI wanted to find out if the compromises made were negatively affecting plant populations. An additional visit was made to each field to do a plant population count 21 to 22 days after seeding.

The targeted and actual plant populations of the nine growers visited are shown in **Table 1**. Only two of the nine growers achieved the recommended plant population of 4 plants per ft<sup>2</sup> (45 plants per m<sup>2</sup>) from the Saskatchewan Pulse Crops Seeding and Variety Guide 2016. It is worth acknowledging that many variables affect plant population including application rate, fertilization, disease, seeding depth, germination, weather, and other factors. However, if the low plant populations result in lower-than-expected yield, the compromises made at time of seeding may be a significant reason why.

**Table 1.** Growers' targeted and actual plant population.

<b>Producer</b>	<b>TKW (grams/1,000 seeds) <sup>[1]</sup></b>	<b>Target Application Rate (lb/ac)</b>	<b>Producers Theoretical Target Plant Population Based on 80% Germination (plants/ft<sup>2</sup>) <sup>[2]</sup></b>	<b>Actual Plant Population (plants/ft<sup>2</sup>)</b>
A	546	400	6.1	3.6
B	546	400	6.1	2.8
C	668	360	4.5	4.2
D	549	300	4.6	4.1
E	734	300	3.4	3.7
F	787	288	3.0	2.8
G	668	250	3.2	3.3
H	717	240	2.8	3.2
I	678	205	2.5	2.8

<sup>[1]</sup>The seed samples that were acquired may not have been representative of the entire seedlot.

<sup>[2]</sup>A laboratory germination test was not conducted on the samples. An estimated germination rate of 80% was used in the above table.

The target application rate of the nine growers varied from 205 to 400 lb/ac with an average of 305 lb/ac. Two growers stated that the vigor of their seed was low; therefore, they targeted a very high application rate (400 lb/ac) to compensate for potentially poor germination rate. The germination rate for these two growers was likely lower than the estimated 80%. The remaining seven growers were close to obtaining their targeted plant populations based on the 80% germination/emergence rates. This suggests their strategies to minimize plugging and other issues did not jeopardize plant stands, but it is not known if yields were affected. There was no evident correlation between the seed size and actual plant population.

#### **4.4 Air Seeder Manufacturer Manual Review**

The operator's manuals for the latest air seeder product offering from each of the following manufacturers were reviewed to glean recommendations for seeding faba beans:

- Bourgault
- Case IH and New Holland

- John Deere
- Morris
- Seed Hawk
- Seed Master

PAMI acknowledges that many older air seeders are still used; however, to limit project scope, the manual review was restricted to current product offerings.

The following sections summarize the relevant information from each of the operator's manuals. As well, PAMI interviewed representatives from each manufacturer to see if there are any recommendations for seeding faba beans that may not have been in each of their manuals. All manufacturers contacted were aware of the struggles that growers have faced when seeding faba beans. All manufacturers have addressed or have efforts underway to improve performance of their products in faba beans.

#### **4.4.1 Bourgault Industries**

Bourgault uses a metering auger rather than metering rollers. The 7000 series manual recommends the high output (HO) auger for large seeds. The application rate/fan speed charts recommend using the chickpea/pea chart for faba beans. The recommended fan speeds for the application rate desired, the configuration of the toolbar, and ground speeds of 4.0 mph to 7.0 mph are presented in the application rate/fan speed charts. The maximum application rate listed in the chart is 400 lb/ac although this rate may not be achievable at all ground speeds and with all toolbar configurations.

On previous models, Bourgault had experienced some collapsing of secondary hoses due to overtightening of hose clamps at the attachment point to the opener. To address this issue, Bourgault has removed material from the seed tube of the opener so the hose clamp is in contact with a greater area of the hose to spread the clamping force over a wider area as shown in **Figure 16**.



**Figure 16.** Updated Bourgault secondary hose clamp method.

#### **4.4.2 Case IH and New Holland**

Case IH and New Holland air seeders are very similar and have been developed by Case New Holland Industrial (CNH). The manual for the Case IH 4000 series recommends the full width metering cartridge for large beans. The metering roller remains the same for all crops. The recommended fan speed for products, such as peas and high rates of fertilizer, is 5,200 to 6,000 rpm. The specifications section states a maximum application rate of 350 lb/ac of fertilizer and a maximum seed diameter up to 3/8 in. CNH is currently developing a new style of metering roller for larger seeds.

#### **4.4.3 John Deere**

John Deere has released a new air cart and toolbar in 2016; however, the operator manual has not been made available yet. The previous model 1910 air cart manual recommends using the blue metering roller for application rates up to 260 lb/ac and metering very large seeds. The recommended fan speed for a single-fan system when the combined product flow rate is 200 to 350 lb/ac, is 4,200 to 4,700 rpm. For a dual-fan system, the recommended fan speed is 2,700 to 3,100 rpm for heavy (200 to 350 lb/ac) application rates of fertilizer

A useful feature in the John Deere air seeder monitor is a flow-rate calculator. Once a target seeding ground speed is entered, the flow-rate calculator predicts the weight of product per minute per primary hose and verifies the ability of the air system to achieve the application rate requirements based on this prediction. It warns the operator if the flow rate is predicted to exceed the maximum limit, which helps avoid plugging once seeding in the field.

John Deere toolbars have an option for 1 1/4 in. inside diameter secondary hoses; however, the diameter of the product flow tube inside the opener does not change. The blockage monitors used on the John Deere toolbar fit over the outside diameter of the secondary hoses instead of inside the secondary hoses, which eliminates a potential restriction to product flow.

#### 4.4.4 Morris Industries

The Morris 9 Series ICT air cart manual explained that Morris does not change out metering rollers for different products. Instead, Morris uses three different seed plates with a fine, medium, and coarse rating that offer varying clearance to the metering rollers for different seed sizes. The coarse seed plate is recommended for beans. A fan speed of 4,650 to 5,000 rpm is recommended for a 17 in. impeller fan and a 41 ft toolbar seeding at 5.0 mph; a total product application rate greater than 350 lb/acre. Morris also incorporates a fan plenum damper adjustment. When seeding large seeds at a rate greater than 180 lb/ac, the damper should be set to open. Morris does have an option for larger diameter distribution flat-fan manifolds (mounted on the toolbar), which accommodate 1.102 in. inside diameter hoses versus the standard 0.945 in. inside diameter hoses which should reduce the prevalence of plugging of faba beans in this area.

To address previous collapsing secondary hose issues (due to overtightening of hose clamps), Morris has incorporated a plate clamping system as shown in **Figure 17**. The two plates squeeze the hose, and the thread length on the bolt will not permit overtightening, which prevents the hose from collapsing.



**Figure 17.** New Morris secondary hose retaining system.

#### 4.4.5 Seed Hawk

The Seedhawk air cart and Toolbar 2016 operator’s manual recommends using the high displacement (application rate of 65 to 320 lb/ac) or coarse displacement (application rate of 40 to 240 lb/ac) metering roller for large beans when seeding at 4.0 to 5.0 mph.

Seed Hawk also provides application rates and theoretical ground speeds that can be achieved at certain application rates as show in **Figure 18**. The maximum listed application rate is 450 lb/ac, although it is at a ground speed of 3.5 mph. These rates are based on a typical fertilizer blend, so they may not be applicable to faba beans.

**NOTE**

Meter RPM is based on a calibration weight of .4244 lb/rev using High Displacement Roller with the rate split between two bins.

**NOTE:**

Due to the many variables associated with application rates ie; humidity, density of product, soil conditions, hydraulic oil temperature etc., this chart is meant as a guideline only.

1/2" Hydraulic Coupler to the Tractor and between Aircart & Toolbar		Fertilizer Blend 125-40-25-25	
Ground Speed	Maximum Rate	Fan RPM1 based on loaded condition	Meter RPM2 based on loaded condition
3.5 mph	360 lb/ac	4100	29.85
4.0 mph	320 lb/ac		
4.5 mph	280 lb/ac		
5.0 mph	252 lb/ac		
5.5 mph	228 lb/ac		

3/4" Hydraulic Coupler to the Tractor and between Aircart & Toolbar		Fertilizer Blend 125-40-25-25	
Ground Speed	Maximum Rate	Fan RPM1 based on loaded condition	Meter RPM2 based on loaded condition
3.5 mph	450 lb/ac	4900	39.18
4.0 mph	400 lb/ac		
4.5 mph	350 lb/ac		
5.0 mph	315 lb/ac		
5.5 mph	285 lb/ac		

**Figure 18.** Seed Hawk application rate table and ground speeds for a typical fertilizer blend (Source: Online Seed Hawk manual).

Seed Hawk has recently released a new metering roller this spring, called a 500cc roller that incorporates greater volume between roller flutes and uses a flexible rubber to accommodate seeding large seeds.

#### 4.4.6 SeedMaster

The 2016 SeedMaster operator’s manual discussed airflow settings, roller types, roller gaps, and application rate range; however, the manual did not specifically discuss seeding of faba beans. Peas are the largest seed listed, so presumably growers refer to pea settings when seeding faba beans.

For the on-frame tank models, the manual recommends using a black roller with a 3/8 in. roller-to-meter housing gap for peas, which will achieve 150 to 200 lb/ac. The manual also recommends increasing the roller-to-meter housing gap if excess seeds are being

crushed by the metering roller. The recommended fan speed is 4,900 to 5,300 rpm for 50 to 100 ft wide toolbars, which should result in 0.94 to 1.12 pounds per square inch (psi) of air pressure. For the Nova tank, a fan speed of 4,100 to 4,400 rpm for the high-flow fan is recommended for peas, and a maximum application rate of 150 to 200 lb/ac is noted for peas.

New product offerings from SeedMaster will have increased clearance between the metering roll flutes and the metering housing to reduce occurrences of seed jamming in the metering housing. New product offerings will also see an increase in the cross-sectional area where the seed drops into the venturi in the product flow tubes to increase product flow capacity.

## **4.5 Comments from Growers Visited**

Comments offered by growers interviewed are detailed below:

- Consider installing vertical distribution towers for less plugging.
- Consider screening seed to remove the largest kernels, which will reduce the probability of plugging by only planting smaller sized seed.
- Be patient and seed at a slower ground speed to prevent issues. The perceived productivity lost will potentially be gained back from fewer plugging incidents, and the field emergence will be better.
- The volume of metering roller flutes varies between type and manufacturer. Some may be more suitable to the high rates required for faba beans than others.
- 1.25 in. inside diameter secondary hoses should be considered rather than the standard 1 in. diameter hoses.
- Be aware that some openers have a bend in the seed tube that collapses the square tube and creates an area for potential plugging.
- Remove any rust from the metering augers and metering housing of air tanks, and replace the metering augers or rollers if worn to prevent plugging in the metering area.
- An opener that can be quickly swapped out for a different style opener would be beneficial so a producer can quickly optimize the opener design for large seeds like faba beans and conversely for small grains.
- Ensure all distribution hoses have the straightest possible path to the opener with no sags or small radius bends.
- Ensure the tractor's hydraulic system has sufficient capacity to maintain the recommended fan speed.
- Consider using planter technology with seed singulation capability for seeding faba beans.
- Reduce the number of tight turns to prevent the innermost openers from reversing in the soil and plugging or restricting flow.

## 5. Conclusions

---

Saskatchewan growers are an innovative group. Many have developed their own methods and configurations to successfully seed faba beans through trial and error in previous years. However, the investigation during this project has shown that current air seeders are not optimized to seed faba beans, especially at the same productivity rate (ac/hr) as other smaller-seed crops. This is understandable as the majority of crops seeded with air seeders are smaller seeds, and faba bean growers are currently a small portion of the air seeder market. It appears that many growers are implementing seeding strategies for faba beans that may be considered as compromises and may be limiting yield potential.

Further research is required to determine the fundamentals of transporting faba beans from the air seeder product tank to the soil in order to match the producer's comfort level when they are seeding faba beans to that of seeding more traditional Saskatchewan crops. The following questions need to be considered to determine the direction of future research:

- Will the requirement for farmers to modify their factory air seeders and compromise on productivity and potentially plant populations inhibit faba bean market growth?
- Are air seeder manufacturers going to better optimize their products in the future for a small-market, large-seed crop such as faba beans? One needs to consider that modifications to air seeders that may improve performance for large seeds may negatively affect performance when seeding small seeds. Alternatively, will they provide recommendations or guidelines for modifications that will improve machinery performance with these crops?
- Can adequate adjustments be designed into air seeders to optimize performance for large and small seeds?



## 6. Recommendations

---

### 6.1 Recommendations for Growers

The following are recommendations for growers to consider when seeding faba beans with air seeders:

- Read your air seeder operator's manual to know its application rate capabilities.
- Ensure the recommended metering roller or auger is installed for large seeds and high application rates.
- Consider metering from multiple tanks to reduce the application rate demand on a single metering system of one tank.
- Consider options to increase the clearance from the metering rollers or augers to the metering housings to reduce the chance of jamming large faba beans in the metering housing or being damaged.
- Target the recommended plant population of 4 plants/ft<sup>2</sup> (45 plants/m<sup>2</sup>).
- Send a representative seed sample to a lab for analysis of TKW, germination percentage, and vigour.
- Use the following formula to determine the application rate:

$$\text{Seed rate in kilograms per hectare} = \frac{\text{target population per square metre} \times \text{TKW in grams}}{\% \text{ field emergence or survival (in whole number, i.e. 85)}}$$

- Ensure there are no tight radiuses or sags in the distribution hoses.
- Eliminate flow obstructions, such as screws, in the distribution hoses.
- Do not overtighten hose clamps such that the hose deforms.
- Use a soil opener with a large-diameter seed opening and minimal change in seed flow direction or seed tube shape.
- Avoid sharp turns so that the inside end of the drill maintains forward speed with the toolbar engaged in the soil.
- To optimize the fan speed, most manufacturers recommend the following process. Refer to **Figure 19** during this explanation. Remove the secondary hose from the opener at one end of the toolbar, then temporarily secure the hose to the frame of the tool bar (Balloon 1). The hose should be no more than 12 in. below the bottom of the frame member (Balloon 2). Ensure the end of the hose is flush with the top of the frame member, the outlet is facing straight up, and the hose is not kinked. Start the flow of the product with the air seeder fan running. From a safe distance, observe the product exiting the hose end. The product (Balloon 3) should discharge about 12 to 24 in. (Balloon 4) above the hose end. Faba beans are more robust than most pulse crops; however, having too much air flow can damage seeds or cause them to bounce out of the desired placement location in the seed bed.

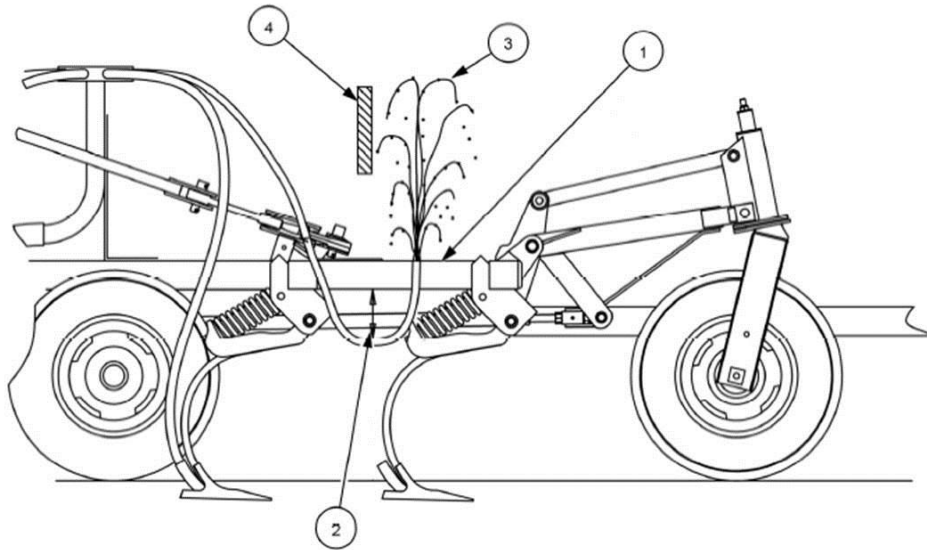

**Figure 19.** A diagram explaining the typical process of setting the fan speed on an air seeder.  
(Source: Case IH Precision Air™ 4000 Series Operator Manuals)

## Appendix A

### Field Visit Data (continued on next page)

Producer	A	B	C	D	E
<b>General Information</b>					
Seeding date	May 7-9	7-May	5-May	16-May	3-May
Years growing faba beans	1	1	2	1	3
Total faba bean seeded area (ac)	160	50	155	300	1500
Total farm seeded area (ac)	3800	4000	2400	3000	6000
Percentage of total seeded acres into faba beans (%)	4%	1%	6%	10%	25%
<b>Seeding Equipment</b>					
Blockage sensors	no	no	no	yes	not for seed, yes for fertilizer
Tool bar width (ft)	55	65	56	38	80
Opener spacing (in)	10	10	10	12	10
<b>Seeding Rate and Plant Count</b>					
Seeding speed (mph)	2.5	2.4	2.2	3.2	4
Area coverage rate assuming no overlap (ac/hr)	16.7	18.9	14.9	14.7	38.8
Seed size in TKW (g/1000 kernels)	546	546	668	549	734
Seed moisture content (%)	13.9%	13.9%	13.6%	13.9%	14.9%
Seed treatment used?	no	no	yes	no	no
Seed size sorting?	no	no	yes	no	yes
Target seeding rate (bu/ac)	6.7	6.7	6.0	5.0	5.0
Target seeding rate (lb/ac)	400	400	360	300	300
Estimated germination rate (%)	80%	80%	80%	80%	80%
Plant population target based on 80% germination (plants / m <sup>2</sup> )	66	66	48	49	37
Actual plant population after 21 days (plants / m <sup>2</sup> )	39	37	45	44	40
Actual plant population ranking out of 9	4	5	1	2	3
<b>Additional information</b>	Screws holding hoses to manifold were too long causing obstruction in hose. Opener style had narrow opening. Installed a few new openers and bent a few openers straight, but plugging still occurred.	Seeding slowly to prevent plugging. Producer stated low vigor and germination rating so increased seeding rate.	Making two passes to achieve 6 bu/acre. Seeding slowly to prevent plugging. Unsure how successful size sorting of seeds was.	Blockage sensors installed, but not using. Had issues with rocks mixed in with his seed. Had highest actual plant population.	Changed out fan to a high capacity fan. Also sieved out top 6% of seed size.

## Field Visit Data – continued (Column F to end).

Producer	F	G	H	I	Averages
<b>General Information</b>					
Seeding date	6-May	16-May	5-May	7-May	
Years growing faba beans	3	3	1	3	
Total faba bean seeded area (ac)	1350	800	155	450	547
Total farm seeded area (ac)	15000	12000	4000	2400	5844
Percentage of total seeded acres into faba beans (%)	9%	7%	4%	19%	9%
<b>Seeding Equipment</b>					
Blockage sensors	yes	no	no	no	2 of 9
Tool bar width (ft)	84	30	53	61	58
Opener spacing (in)	12	7	10	12	
<b>Seeding Rate and Plant Count</b>					
Seeding speed (mph)	4.7	5.3	3.1	4.5	3.5
Area coverage rate assuming no overlap (ac/hr)	47.9	19.3	19.9	33.3	24.9
Seed size in TKW (g/1000 kernels)	787	668	717	678	655
Seed moisture content (%)	13.2%	15.2%	12.2%	14.1%	13.9%
Seed treatment used?	no	yes	no	no	2 of 9
Seed size sorting?	no	no	no	yes	2 of 9
Target seeding rate (bu/ac)	4.8	4.2	4.0	3.4	5.1
Target seeding rate (lb/ac)	288	250	240	205	305
Estimated germination rate (%)	80%	80%	80%	80%	80%
Plant population target based on 80% germination (plants / m <sup>2</sup> )	33	34	30	27	43
Actual plant population after 21 days (plants / m <sup>2</sup> )	30	36	34	30	37
Actual plant population ranking out of 9	9	6	7	8	
<b>Additional information</b>	Seeding out of fertilizer outlet. Metering rollers damaged due to seeds jamming.	Previously tried broadcasting seed and working in with vertical tillage unit which resulted in poor emergence.	Metering seed out of 2 tanks on tow between tank and fertilizer out of tow behind tank. Seeding slow to prevent plugging.	Seed sorting equipment used 32 round to sculpt, 14 slots to sift. Kept large seeds.	

## Appendix B

### Phone Survey Data (continued on next page)

Producer	J	K	L	M	N	O	P	Q	R
Years growing faba beans	3	1	2	1	1	1	1	1	2
Total faba bean seeded area (acres)	380	140	400	680	140	160	2000	160	280
Total farm seeded area (acres)	6500	15000	7500	10900	Unknown	16000	9500	4000	7500
Percentage of total seeded acres into faba beans (%)	6%	1%	5%	6%	Unknown	1%	21%	4%	4%
<b>Seeding Equipment</b>									
Tool bar width (ft)	41	90	80	60	84	70	84	Unknown	50
Opener spacing (in.)	10	12	12	10	Unknown	10	12	12	10
<b>Seeding Rate and Plant Count</b>									
Seeding speed (mph)	2.7	4	5	4	2.5	3	Unknown	4	3
Area coverage rate assuming no overlap (ac/hr)	13.4	43.6	48.5	29.1	25.5	25.5	Unknown	Unknown	18.2
Target seeding rate (bu/ac)	4.2	5.0	4.0	4.8	6.3	4.5	4.5	4.4	4.0
Target seeding rate (lb/ac)	250	300	240	285	378	270	270	264	240
<b>Additional information</b>	Issues with plugged hoses. Seed coated with seed treatment and inoculant which increased size of seed and increased plugging from previous years.	Reduced metering roller diameter by 0.5 in to reduce damage to seed and rollers	Initial metering rollers did not work. Newly released dry bean rollers worked well	Seeded out of two tanks. Had issues with hose clamps collapsing hoses and causing plugging	Targeted 420 lb/ac application rate, but could only achieve 378 lb/ac. Seeded slow to avoid plugging	Plugged when seeding out the side of the disc. Routed seeds down center of disc where fertilizer would normally be routed which reduced plugging.	Seeds were very large. Wishes he would have used the rollers recommended for chickpeas. Would have liked to try the Flexicoil distribution manifolds.	Seeded twice over to at 2.2 bu/acre to achieve 4.4 bu/ac. He had issues plugging at openers. He believes rust in the openers restricted flow of beans. Once opener tubes were shined up flow was better and could achieve high rate over one pass at 4.2 mph. Baffle plates in cart caused issues.	Had very few issues due to learning in previous year to slow down. Had very large seeds this year. If they get any larger they will not flow through his air seeder.

## Phone Survey Data – continued (Column S to end)

Producer	S	T	U	V	W	X	Y	Z	AA	AB	AC	Averages
Years growing faba beans	3	1	2	3	1	1	1	3	2	1	3	
Total faba bean seeded area (acres)	135	280	1600	200	140	125	330	300	95	20	1000	428
Total farm seeded area (acres)	4500	3600	13000	5000	1800	3150	2900	1800	500	Unknown	5600	6597
Percentage of total seeded acres into faba beans (%)	3%	8%	12%	4%	8%	4%	11%	17%	19%	Unknown	18%	8%
<b>Seeding Equipment</b>												
Tool bar width (ft)	42	72	54	60	47	60	70	35	40	Unknown	69	62
Opener spacing (in.)	7.5	12	10	12	10	12	12	10	10	12	12	
<b>Seeding Rate and Plant Count</b>												
Seeding speed (mph)	2.7	3	3.75	3.5	2.3	2.9	3.2	4	3.4	1.7	4.5	3.3
Area coverage rate assuming no overlap (ac/hr)	13.7	26.2	24.5	25.5	13.1	21.1	27.2	17.0	16.5	Unknown	37.6	25.1
Target seeding rate (bu/ac)	4.5	4.8	4.0	5.0	4.0	4.3	4.8	4.0	3.5	2.0	3.8	4.3
Target seeding rate (lb/ac)	270	285	240	300	240	260	285	240	210	120	225	259
Additional information	<p>Damaged the large blue roller. Suggests a higher capacity roller is needed. Started at 5 mph, but plugged immediately so slowed down. Had larger seeds than in previous years. Neighbour had 3/4 in secondary hoses which did not work. Would like to see 1.25 in diameter secondary hoses</p> <p>Had plugging issues in primary hoses just before distribution towers. Blockage sensors did not sense since they were on secondary hoses. Suspects he may have been using the wrong roller and or seeding too heavy.</p> <p>Had plugging issues at entry into openers. Removed square transition (seed brake) and inserted hoses directly into openers.</p> <p>Started at 5.0 mph and had plugging issues in primary hoses. Reduced speed to 3.5 mph then had no plugging issues. Sent seed down the center of the opener. Double treated the seed which increased size and made seeds sticky. Seeded out of two tanks to achieve high rate.</p> <p>Square seed boot caused plugging issues. Unplugged runs every 1/2 mile. Took 2 days to seed 140 acres.</p> <p>Seeded from two tanks to achieve high rate. Started at 4.0 mph and had primary lines plug up. Slowed down to 2.9 mph and had no issues. Treated seed twice with Trilex which makes seeds sticky and inhibits flow.</p> <p>Had issues with rollers jamming so added a second hydraulic motor to right side to increase torque to metering shaft. Blockage sensors caused plugging. TKW was 620 g/1000 while his Snowbird variety was 430. Had no issues with the Snowbird variety.</p> <p>Had dirty seed so pieces of stubble plugged the manifolds.</p> <p>Seeds may have been larger this year. Plugged distribution towers at the outlets occasionally. The slower he seeded the better the flow was.</p> <p>Could only achieve 120 lb/ac. Plugged primary pipe where the pipe was flattened slightly due to bend radius. Seed won't pass through to bottom primaries on double shoot drill.</p> <p>Maximized fan speed and metered from two tanks. Sorted seed to remove large seeds with a #28 round screen. Plugged at Seedmaster venturi cup and Bourgaui secondary towers. Suggested better offering of weed control needed. Has been averaging 14 bu/ac because of weed pressure.</p>											



**Saskatchewan Operations**

Box 1150  
2215 – 8<sup>th</sup> Avenue  
Humboldt, SK S0K 2A0  
1-800-567-7264

**Manitoba Operations**

Box 1060  
390 River Road  
Portage la Prairie, MB R1N 3C5  
1-800-561-8378

**Corporate Services**

Box 1150  
2215 – 8<sup>th</sup> Avenue  
Humboldt, SK S0K 2A0  
1-800-567-7264